

**FINEST
QUALITY
FASTENERS**



BOLTS



NUTS



WASHERS

OVER 21 YEARS OF EXPERIENCE IN INDUSTRIAL & AUTOMOTIVE FASTENERS

It all started in Year 2000 with a typewriter, and dream of our Managing Director (Mr. Rishi Gupta) to become a reliable source for High quality fasteners from India.

Since then KOVA has been selling fasteners in more than 40 countries across the globe and has grown to become a 15 Million USD Company, and is aiming to become a 50 Million USD company in next 5 years.

Spread across 70000 SQ FT. Area with installed capacity of 750 Metric tons of fasteners per month and having a team of 300+ Dedicated employees working in 2 shift to deliver Quality fasteners.



Vision of our Managing Director



Each and every fastener delivered under the name of KOVA has been exclusively manufactured in India using the most up-to-date technology, time-tested processes, evolving practices, and skilled resources.

We understand every technical detail required to make high-quality Fastener. All processes such as forging, thread rolling, heat-treatment, and plating are carried out at our own state-of-the-art manufacturing unit under the supervision of an adroit team of professionals and engineers.



QUALITY PRODUCTS

KOVA, is certified for "IATF 16949 : 2016" for the production of high quality automotive fasteners and "CE" for the production of structural bolting assemblies as per EN 15048 & EN 14399. Our state of the art production unit ensures durable product with excellent finishing.

Multiple tests and checks are done at every stage of production process to ensure the chemical, mechanical and dimensional accuracy of each and every fastener.



EN 15048:2007 & EN 14399:2015



IATF 16949:2016

INFRASTRUCTURE

Our state of the art new plant is designed with modern infrastructure and is **one of the cleanest fastener units in India**



LIST OF MACHINERY

	NAME OF MACHINE	RANGE	QUANTITY
1	High Speed Multi-Station Bolt Makers	M5 - M24	18 No.
2	Nut Formers	M5 - M16	4 No.
3	Thread Rolling Machines	M5 - M24	20 No.
4	Hydraulic Thread Rolling		1 No.
5	Hydraulic Press		1 No.
6	Lathe Machines		8 No.
7	Nut Tapping Machines	M5 - M24	8 No.
8	Automatic Drilling Machine		6 No.
9	EDM machine		1 No.
10	Polish Adda		2 No.
11	Engraving Machine		1 No.
12	Continuous Heat Treatment Furnace	250 kgs/Hour	4 No.
13	Zinc Plant Semi-Automatic		4 Barrels
14	Wire Processing / Drawing Plant		2 No.

COLD FORMING SECTION



THREADED ROLLING



HEAT TREATMENT



RAW MATERIAL



STORE ROOM



PACKAGING

Each product is checked at every stage of production and packed with great care to ensure the quality is not compromised in any way.



TESTING FACILITIES

At Kova Fasteners Pvt Ltd., we focus on full batch traceability of every product that is manufactured at our unit, starting from chemical composition a unique batch number is created for every product which is carried throughout at every stage of production. This unique batch number is also labeled on the packaging of the product.

NON DESTRUCTIVE TEST EQUIPMENTS		RANGE	QUANTITY
1	Hardness Tester Rockwell	HRB / HRC	2 No.
2	Hardness Tester Vicker Scale		1 No.
3	Profile Projector		1 No.
4	Metallurgical Microscope		1 No.
5	B. F. Testing Machine For Carrogated Box		1 No.

DESTRUCTIVE TEST/MECHANICAL TEST EQUIPMENTS		CAPACITY	QUANTITY
1	UTM (Universal Testing Machine)	40 TON / 100 TON	2 No.
2	Impact Testing Machine		1 No.
3	Spectrometer		1 No.

ELECTROPLATING INSTRUMENTS		QUANTITY
1	Salt Spray Chamber	1 No.
2	Coating Thickness Guage	2 No.



**AUTOMOTIVE
FASTENERS**



**INDUSTRIAL
FASTENERS**



**STRUCTURAL
FASTENERS**







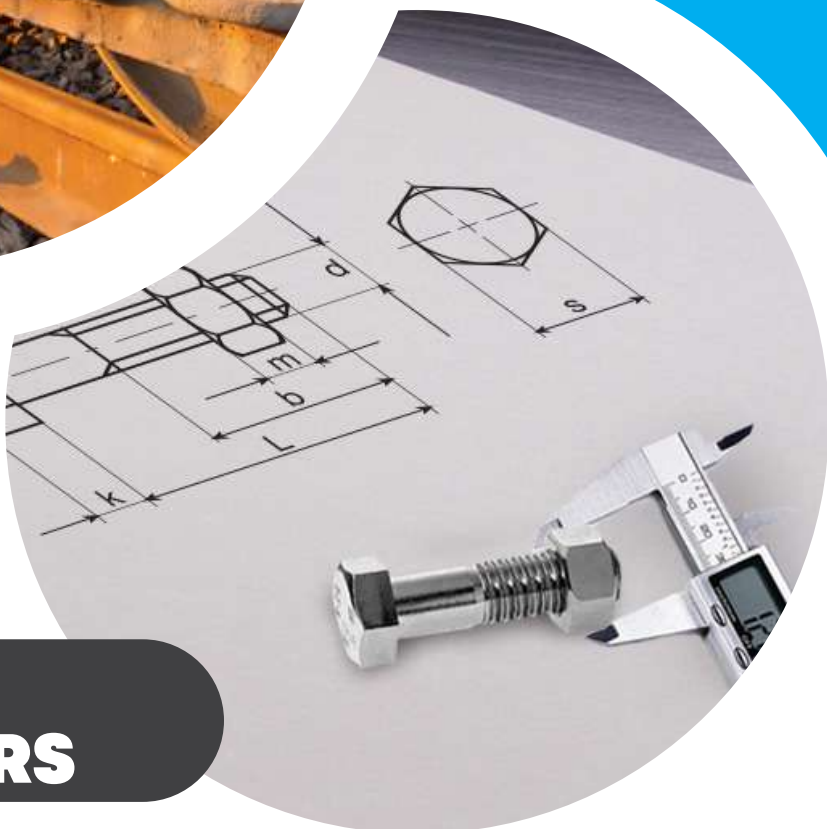

AGRICULTURAL FASTENERS



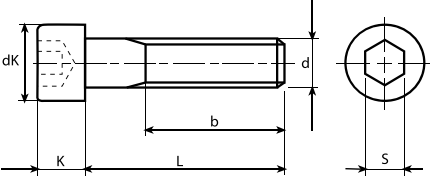

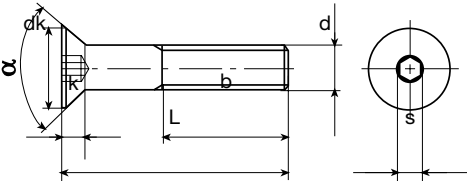

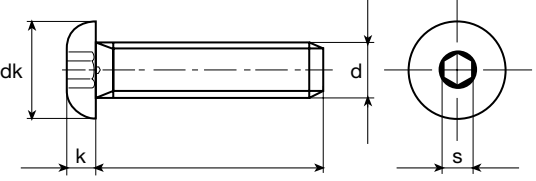

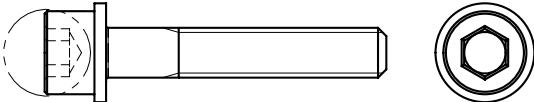
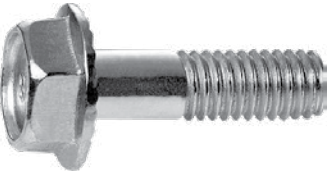
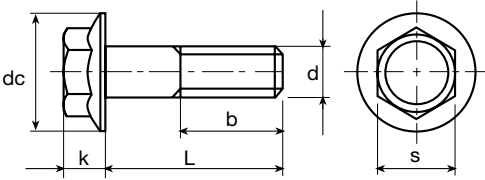
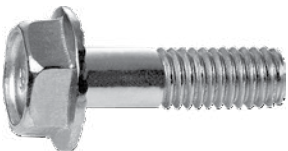
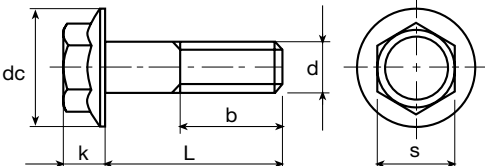
RAILWAYS FASTENERS



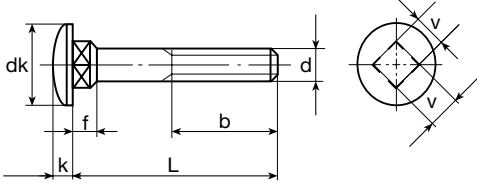
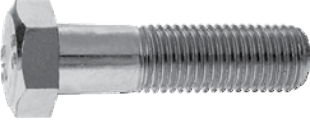
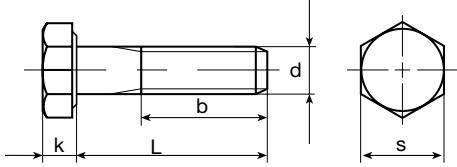

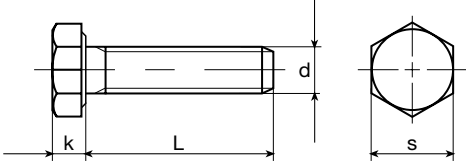

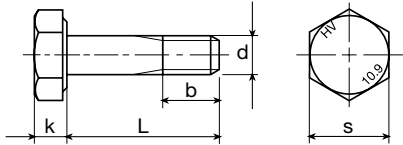

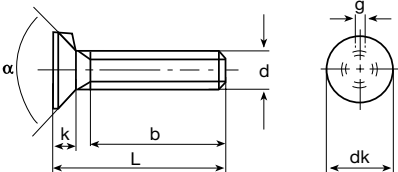
SPECIAL FASTENERS

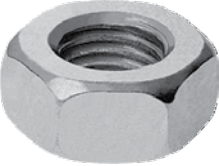
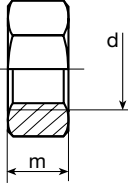
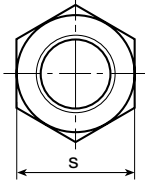
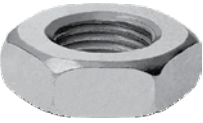
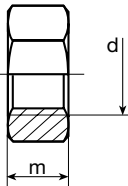
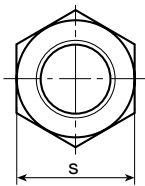
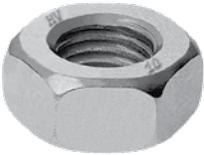
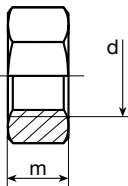
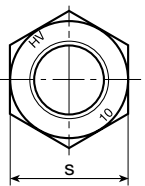

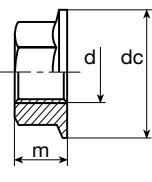
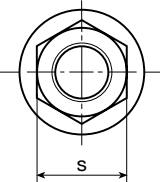

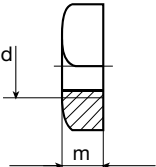
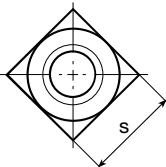

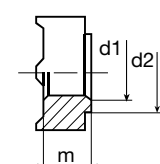
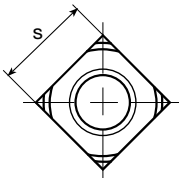
	Size	Grade	Finish Available	Standard	
				Din	ISO
<p>Socket Head Cap Screws</p> 	M5 to M20	8.8, 10.9, 12.9	Black, Zinc, HDG	912	4762
					
<p>Socket Countersunk Head Screws</p> 	M5 to M20	8.8, 10.9	Black, ZINC, HDG	7991	
					
<p>Socket Button Head Screws</p> 	M5 to M12	8.8, 10.9	Black, ZINC	7380	7380
					
<p>Flange Socket Head Cap Screws</p> 	M5 to M12	8.8, 10.9, 12.9	Black, ZINC		
					
<p>Flange Bolts</p> 	M5 to M16	8.8, 10.9, 12.9	Black, ZINC, HDG	6921	8100
					
<p>Flange Bolts With Serration</p> 	M5 to M16	8.8, 10.9, 12.9	Black, ZINC, HDG	6921	8100
					

BOLTS

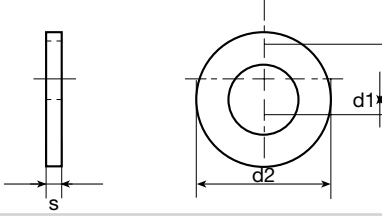
	Size	Grade	Finish Available	Standard	
				Din	ISO
Mushroom Head Square Neck Bolts	M6 to M20	4.8, 8.8	Black, ZINC, HDG	603	8677
					
Hex Head Bolts Partial Threaded	M5 to M30	4.6, 4.8, 5.6, 5.8, 8.8, 10.9, 12.9	Black, ZINC, HDG	931	4014
					
Hex Head Screws Full Threaded	M5 to M30	4.6, 4.8, 5.6, 5.8, 8.8, 10.9, 12.9	Black, ZINC, HDG	933	4017
					
High Strength Structural Bolts	M12 to M20	8.8, 10.9	Black, ZINC, HDG	1614	7412
					
Flat Countersunk Nib Bolts	M6 to M20	8.8, 10.9	Black, ZINC, HDG	614	
					

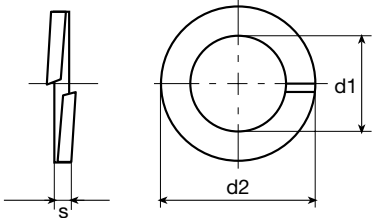
	Size	Grade	Finish Available	Standard	
				Din	ISO
Hex Nuts	M5 to M30	4, 6, 8, 10	Black, Zinc, HDG	934	4032
					
Thin Hex Nuts / Lock Nuts	M8 to M30	8, 10	Black, ZINC, HDG	936	
					
High Strength Structural Hex Nuts	M12 to M30	8, 10	Black, Zinc, HDG	6915	7414
					
Flange Nuts With Serration	M6 to M20	8, 10	Black, Zinc, HDG	6923	4161
					
Square Nut	M6 to M12	8, 10	Black, Zinc, HDG	557	
					
Square Weld Nut	M6 to M12	8, 10	Black, ZINC, HDG	928	
					

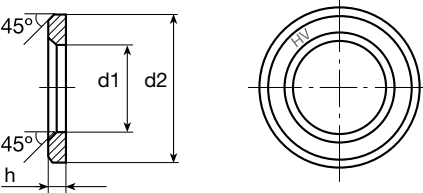
WASHERS

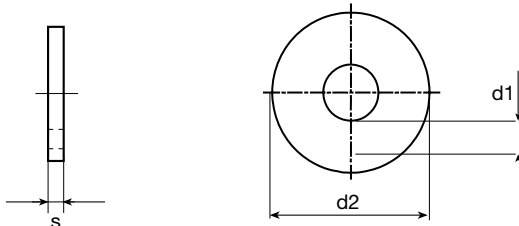
	Size	Grade	Finish Available	Standard	
				Din	ISO
Plain Washers	M5 to M30		Black, Zinc, HDG	125-A	7089
					
Spring Lock Washers	M5 to M30		Black, ZINC, HDG	127-B	
					
High Strength Structural Washers	M12 to M30		Black, Zinc, HDG	6916	7416
					
WASHERS- DIN 9021	M3 to M24		Black, Zinc, HDG	9021	7093
					



GLOBAL PRESENCE

Catering to the demands of a wide spectrum of industrial sectors in five continents, we take pride in being able to penetrate international markets with our superior products, genuine pricing, high service standards and strong business ethics. With a client base in 40 nations and counting, we satisfactorily meet the needs of a variety of market sectors ranging from civil engineering to infrastructure development and automotive industries with the help of our trusted logistical partners.

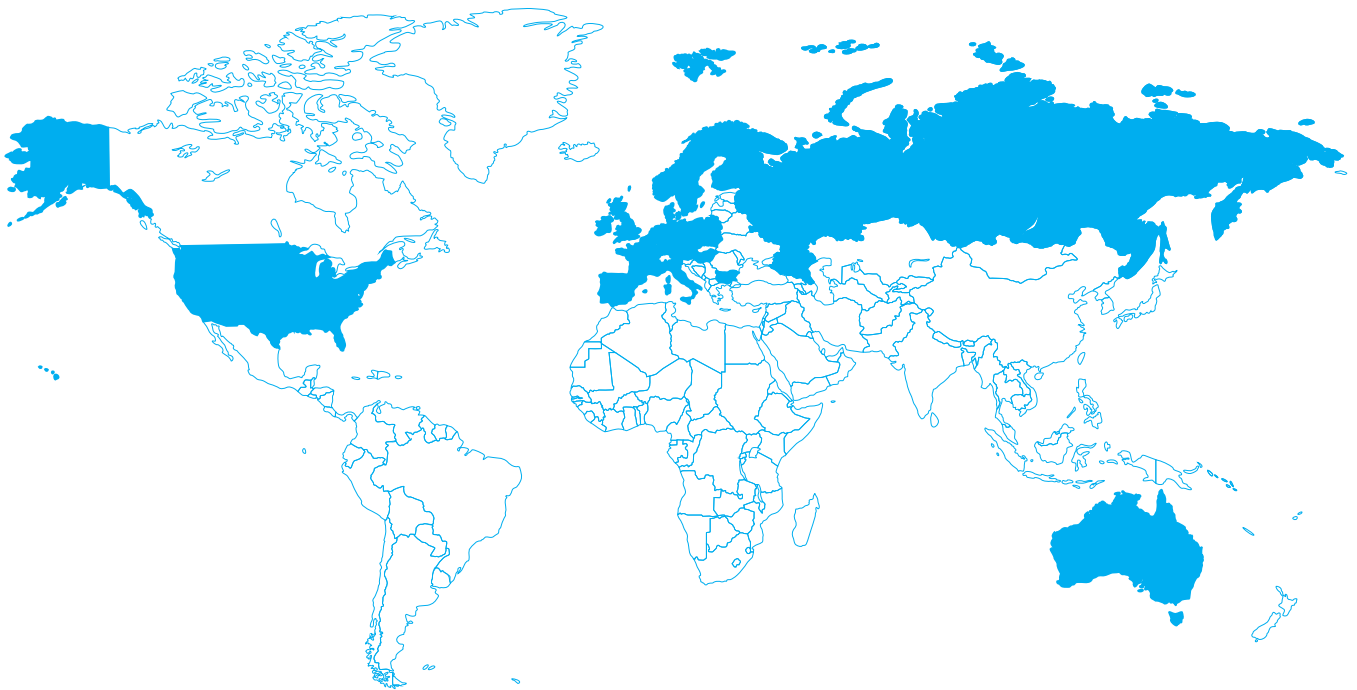

Australia*
Austria
Belgium
Bulgaria
Czech Republic
Denmark
Finland

France
Germany
Hungary
Ireland
Italy
The Netherlands
Norway

Poland
Portugal
Russia*
Spain
Sweden
United Kingdom*
United States
and many more...

EXHIBITIONS

KOVA has been regularly participating in various Trade Shows worldwide.



FASTENERS FAIR BUDAPEST	2010
FASTENERS FAIR BRAZIL	2011
HANNOVER MESSE	2012
FASTENERS FAIR STUTTART	2013
HARDWARE SHOW GERMANY	2014
FASTENERS FAIR STUTTART	2015
FASTENERS FAIR STUTTART	2017

AUTO EXPO NEW DELHI	2018
INTERNATIONAL FASTENERS EXPO	2018
LAS VEGAS USA	2018
FASTENERS FAIR STUTTART	2019
AUTO EXPO NEW DELHI	2020
FASTENERS FAIR MUMBAI	2021



KOVA[®]
TOUGH BY NATURE



www.kova.in
www.kovafasteners.com

Get in touch
KOVA Fasteners Pvt Ltd.

📍 B-30 - 1858/2B, Focal Point, Phase - IV,
Sherpur Kalan, Ludhiana - 141010, Punjab, INDIA.

📞 +91 161 463 1535

Domestic/India:

✉️ enquiry@kova.in 📞 +91 82640-96715

International/Export:

✉️ export@kova.in 📞 +91 98157-43535